

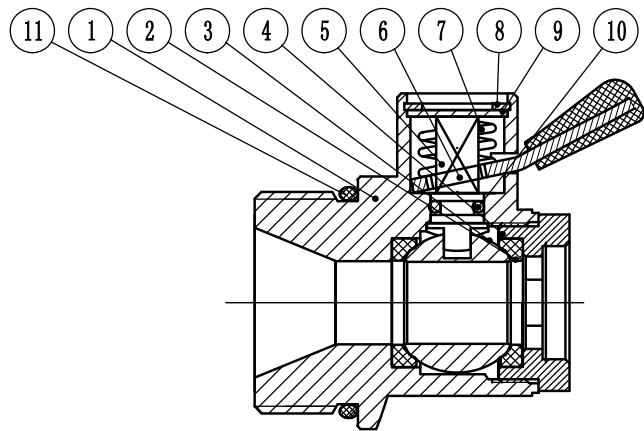

TECHNICAL DATA SHEET

The EZ Oil Drain Valve is a simple, user-operated valve device designed to allow the easy draining of oil from petrol, diesel and gas engine sumps. Incorporating a double-action locking mechanism to secure the valve from unintentional activation. Designed for reliability and longevity. Typical usage is the replacement of the standard engine drain plug with an EZ Oil Drain Valve.

MATERIALS		
1	Body	Forged Brass, Nickel plated
2	Seat	PTFE M-111
3	Ball	Brass, Chrome plated
4	End Cap	Brass, Nickel plated
5	Stem	Brass
6	Lever	Stainless Steel 304
7	Spring	Stainless Steel 304
8	Circlip	Stainless Steel 304
9	Top plate	Stainless Steel 304
10	Stem O-ring	Viton 70 Shore
11	Flange O-ring	Viton 90 Shore



OPERATING RANGES		
Pressure	1724kPa (250psi)	
Temperature	-30°-185°C (-30°-365°F)	

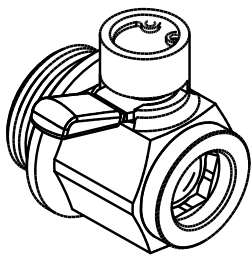

Vibration	Oscil. 3mm, Acc. 6.8G, Freq. 2000Hz JIS D1601	PASS
Strength test - body/stem	5MPa (725psi) (no failure)	PASS
Strength test - ball	5MPa (725psi) (no failure)	PASS
Viton temp. hardness	JIS K6301	PASS
Open/close durability	28,453 cycles (no failure)	PASS

ACCESSORIES	
90 degree hose end	Brass, Nickel plated
Straight hose	Brass, Nickel plated
Adaptor/extension	Brass, Nickel plated
Cap	Anodised Aluminium

